

We are looking for a master student to work on:

# Integrated Battery Charger for Multiphase Traction Motor Drives

## Background

This work is related with the European project FITGEN (<https://fitgen-project.eu/>), aiming at developing and testing an advanced functionally integrated e-axis for electric vehicles. Among the other tasks, PoliTo is required to evaluate innovative solutions for On-board Battery Chargers (OBC), and in particular possible integration of the OBC with the traction drive.

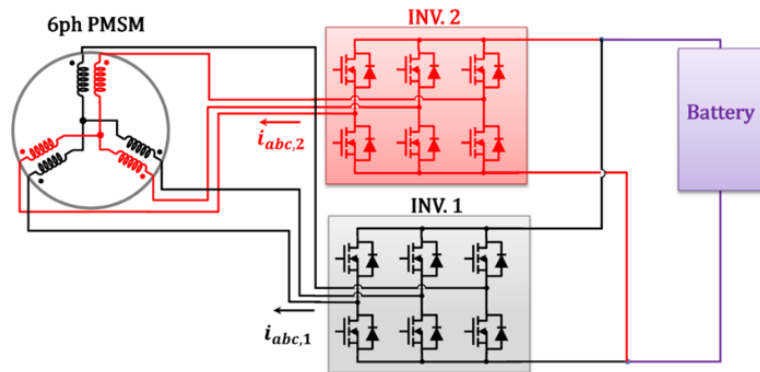

Fig. 2: 6-phase traction drive for electric vehicle

The basic idea of integrated battery chargers (IOBC) is to exploit the vehicle motor and inverter also for battery charging. The drive can be reconfigured in traction mode (see Fig. 1) or in battery charging mode. In the latter, the motor is used as a reactive element (PFC boost inductor or isolation transformer), while the inverter regulates the energy conversion. In particular, the FITGEN project is developing a 6-phase traction motor drive, which gives additional degrees of freedom for the machine reconfiguration respect to traditional 3-phase motors (see an example in Fig. 2).

At the present status of the work, several possible topologies for isolated IOBCs have been simulated using PLECS, and a traction synchronous motor is available for experimental validation.

## Your tasks

- 1) Complete the PLECS simulation and systematically evaluate the correct operation of the integrated charger in every possible working point.
- 2) Participate to experimental validation of the integrated charger on the 6-phase 96 kW traction drive (if possible considering the pandemic situation).
- 3) Optimization of the charging control strategy.

The student work will focus on the points 1) and/or 2) depending on the candidate availability. The point 3) should be considered optional.

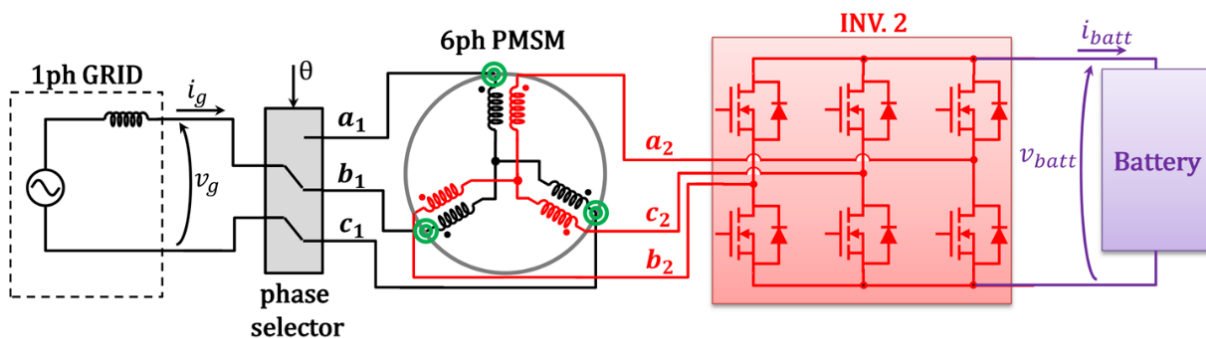

Fig. 1: Drive reconfiguration for integrated on-board charger.

### Necessary skills

- Electrical Engineering Master student or equivalent;
- Basic knowledge of digital control;
- Basic knowledge of electrical machine modeling and control;
- C programming skills;
- Problem-solving skills.

### What you will learn

- Advanced simulation using PLECS;
- Non-standard control of power electronic converters and drives;
- Experimental skills: how to implement a control on a real test bench, including grid interface, drive control, measurement equipment and how to report the results of the experimental activity.

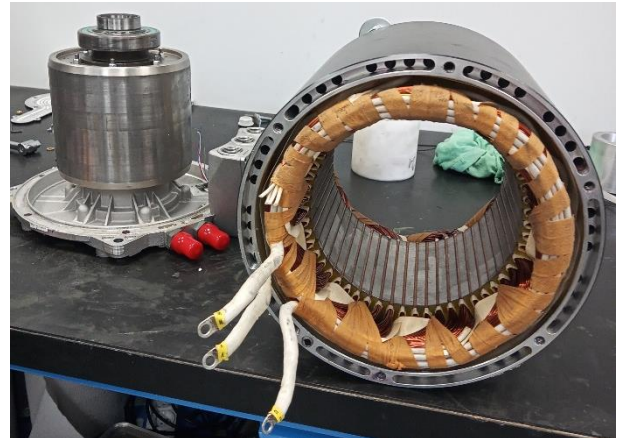

*Fig. 3: Stator and rotor of the 6-phase traction motor*

**Duration of the thesis:** 6 months

### Additional material

Additional information on the topic and material can be found here:

[https://www.dropbox.com/sh/4psnhtdncgy3ean/AABHroD7Hf3ZP4ML\\_9A7I0Qba?dl=0](https://www.dropbox.com/sh/4psnhtdncgy3ean/AABHroD7Hf3ZP4ML_9A7I0Qba?dl=0)

### Application

We are looking forward to receiving your application. Please include your CV and a short explanation why you fit the position (Italian or English). Send your application to [gianmario.pellegrino@polito.it](mailto:gianmario.pellegrino@polito.it) and [paolo.pescetto@polito.it](mailto:paolo.pescetto@polito.it).